

# FLAME INNOVATION



UL 1482-2022    CAN/ULC-S627:2023  
ASTM E2779, 40 CFR 60 AAA  
Project # 24-266

**Mini Me Pellet**

# Mini Me Pellet Tiny Stove Installation and Operation Manual

Run Number	Date	Segments		Run Time (min)	Heat Output (BTU/hr)	1st Hr Emissions (g/hr)	Integrated Total (g/hr)	CO Emissions (g/min)	Overall CO Emissions (g/min)	Heating Efficiency (%HHV)	Overall Heating Efficiency (%HHV)
		Setting	BR								
2	8/14/2024	OA	1.22	360	17609	1.2	0.36	0.22	0.22	76%	76%
		H	2.07	60	29388			0.17		74%	
		M	1.34	120	19167			0.23		75%	
		L	0.86	180	12567			0.23		77%	

**EPA UL / CSA MOBILE HOME APPROVED USA / CANADA**

**This stove needs to be installed with the correct pipe as tested and listed below.  
Failure to do so will void the warranty of the stove.**

Mini Me Non-Electric, Gravity Fed Pellet Stove w/ 38-40 lb. Hopper and removable pellet adapter. Pellet Feed Shut off Tool.  
Brick Fire Pot and Removable Ash Pan.

Manufactured by 509 Fabrications, Inc.  
DBA, Flame Innovation  
6512 W. Seltice Way  
Post Falls, ID 83854 USA

[info@509Fab.com](mailto:info@509Fab.com)



Proudly Made in the USA

Rev. 7.0

09/2024

**CAUTION:** This unit must be installed in accordance with these instructions and must comply with local building and fire codes. Failure to do so could result in a chimney or house fire. Keep children, furniture, fixtures, and all combustible materials away from any heating appliance. Refer to this owner's manual for all clearances to combustible materials.

**This pellet heater needs periodic inspection and repair for proper operation. This pellet heater has a manufacturer set minimum low burn rate that must not be altered. It is against federal regulations to alter this setting or otherwise operate this pellet heater in a manner inconsistent with the operating instructions in this manual.**

**Disclaimer: All Pellet stoves burn differently in how they are controlled, Type and BTU content of pellets used, Elevation and height of chimney, etc. Pellets Tested are soft wood pellets with a moisture content of approx. 9% produced consistent burn times of 10 plus hours. Hardwood Pellets were not tested.**

It is the consumer's responsibility to ensure the chimney system is safe and in good operating condition. **The manufacturer will not be held responsible for an accident attributed to a unit connected to a faulty chimney system or improper chimney parts. This stove carries a 5-year warranty on the stove body. No warranty on paint, glass, or consumable parts such as bricks and pellet adapter. Any shipping damage must be reported immediately upon receiving shipment to ensure replacement or repair from a warranty claim through the shipping company. Any warranty claims must be submitted in writing with pictures to our email info@509fab.com.**

**\*IMPROPER INSTALLATION:** The manufacturer will not be held responsible for damage caused by the malfunction of a stove due to improper installation, CHIMNEY FIRES OR OVER-FIRING THE STOVE. It is especially important to use only specified Components when installing. Do not use makeshift methods or material which may compromise the installation. Improper Parts used can cause chimney fire and poor stove performance including exposure to carbon Monoxide. 509 Fabrications, Inc. DBA Flame Innovation will not be liable for consequential or indirect damage to property or persons resulting from the use of this product. Consult a professional installer if you have any questions.

## SAVE THESE INSTRUCTIONS

**ANY AND ALL SAFETY PRECAUTIONS MUST BE TAKEN AT ALL TIMES DURING OPERATION AND MAINTENANCE OF YOUR STOVE.** Read this entire manual before you install and use your new room heater. If this heater is not professionally installed, a structure fire may result. To reduce the risk of fire, follow the installation instructions. Failure to follow instructions may result in property damage, bodily injury, or even death.

**CAUTION:** *Stove is heavy (107 #) In addition, when handling any sheet metal products, be aware that there may be sharp edges or burrs. Although we make every effort to eliminate any sharp edges, please use caution when handling any metal parts. Remember to always allow the stove to completely cool down before performing any maintenance.*

**CAUTION:** If you have any doubt concerning your ability to complete your installation in a professional-like manner after reading these instructions, you should obtain the services of an installer who is versed in all aspects as to the correct and safe installation. Do not use temporary, makeshift compromises during installation.

## Precautionary Statements

Flame Innovation highly recommends the use of **Smoke Detectors and Carbon Monoxide Detectors** with any hearth product, including this unit. Follow all manufacturer's instructions when using smoke or Carbon Monoxide detectors. **DO NOT INSTALL THIS STOVE IN A SLEEPING ROOM**

**CAUTION ONCE AGAIN PLEASE READ AND FOLLOW.** If you have any doubt concerning your ability to complete your installation in a professional-like manner after reading these instructions, you should obtain the services of an installer who is versed in all aspects as to the correct and safe installation. Do not use temporary, makeshift components during installation.

**WARNING: THINGS TO REMEMBER IN CASE OF A CHIMNEY FIRE: 1. CLOSE DRAFT CONTROL 2. PUT IN THE PELLETT STOP TOOL 3. CALL THE FIRE DEPARTMENT**

#### BEFORE INSTALLATION OF YOUR APPLIANCE

**HOT** WHILE IN OPERATION. KEEP CHILDREN, CLOTHING AND FURNITURE AWAY. CONTACT MAY CAUSE SKIN BURNS. DO NOT BURN GARBAGE OR FLAMMABLE FLUIDS.

1. Check with the building inspector's office for compliance with local codes; a permit may be required.
2. A 4" diameter Class A Flue pipe is required for proper performance. 2' to 3' Single wall Stainless Steel pipe can be installed off the top of the stove if you can maintain 12" Clearance to combustibles until the use of Class A HT Insulated pipe is required.
3. Always connect this unit to a chimney and up through and NEVER vent to another room or inside a building.
4. DO NOT connect to any duct work to which another appliance is connected, such as a furnace.
5. DO NOT connect this unit to a Chimney Flue serving another appliance.
6. **DO NOT USE CHEMICALS OR FLUIDS TO START THE FIRE.**
7. The connector pipe and chimney should be inspected periodically and cleaned if necessary.
8. Remember the clearance distances when you place furniture or other objects within the area. (**DO NOT** store wood, flammable liquids or other combustible materials too close to the unit.)
9. Contact your local fire authority for information on how to handle a chimney fire. Have a clearly understood plan to handle a chimney fire. In a chimney fire, turn the air control to a closed position, **SLIDE IN THE PELLETT SHUTOFF TOOL** and **CALL THE FIRE DEPARTMENT.**
10. DO NOT tamper with the combustion air control beyond normal adjustment.
11. Once the required draw is obtained, operate only with door closed; open feed lid slowly when refueling.
12. Clean the stove glass before lighting the stove.
13. Visit our web site at [FlameInnovation.com](http://FlameInnovation.com) or email us at [Cody@509Fab.com](mailto:Cody@509Fab.com) / [Dusty@509Fab.com](mailto:Dusty@509Fab.com)

ALWAYS PROVIDE A SOURCE OF FRESH AIR INTO THE ROOM WHERE THE UNIT IS INSTALLED. FAILURE TO DO SO MAY RESULT IN AIR STARVATION OF OTHER FUEL BURNING APPLIANCES AND THE POSSIBLE DEVELOPMENT OF HAZARDOUS CONDITIONS IN SMALL AREAS.

**Note on Outside Air Hookup:** The Mini Me Pellet Stove comes with an ash pan with a 3" Fresh air outlet on the rear bottom of the stove. **We highly recommend fresh air for tiny spaces.** This involves connecting an aluminum flex pipe (usually three inches (3") in diameter from the air inlet pipe located on the back leg and to the ash Pan adapter through your floor or wall. The outside end of this pipe should be covered in some manner (i.e., with a screen) to keep it clear of foreign matter. Be sure to keep it above the snowdrift line and clear of leaves and other debris. It is not recommended to use a screen with openings smaller than: ¼" x ¼" **DO NOT USE A SCREEN SO FINE IT INHIBITS AIR FLOW.**

## FLUE SYSTEM

The Mini Me Pellet Stove is designed for use with a 4" Flue System. DO NOT USE BIGGER PIPE. Use a Minimum 24ga. Stainless Steel pipe, up until Minimum 18" from the ceiling, before transitioning to Class A 4" Pipe for 2" Clearance to combustibles around the pipe only, not the stove at any time.

**(The black or non-painted single wall connector pipe should be at least 24ga. Stainless Steel and a minimum of 12 inches (12.0") from a combustible wall and eighteen inches (18.0") from ceiling before transitioning to the Class A pipe to go through the wall or ceiling.**

**MINIMUM OF 7 FT OF PIPE WITH AT LEAST ½ BEING INSULATED PIPE IS REQUIRED TO BURN.**

It is permissible to use single wall pipe and Class A pipe both if you follow your counties rules and regulations with no single wall pipe penetrating any surface without 18" Clearance to combustibles around it. It is recommended in this situation to convert to Class A pipe at the ceiling box transition.

**Canada: A Chimney connector shall not pass through an attic or roof space, closet or similar concealed space, or a floor, or ceiling. Where passage through a wall or partition of combustible construction is desired. The installation shall conform to CAN/CSA-B365. Installation code for Solid-Fuel-Burning Appliances and equipment.**

**It is not permissible to connect this unit to a chimney that is servicing another unit.**

**Flue Size-**The proper flue size is determined by measuring the inside diameter of the flue collar on the unit. This stove is equipped with a four-inch (4") TOP EXHAUST FLUE COLLAR. Therefore, the connector pipe should be four inches (4") only and never less in diameter than the collar on the stove. Your unit may require an adapter which will reduce the 4" connector pipe by 1/8". This is necessary to accommodate pipe variation from different manufacturers and maintain a good seal. All Joints should be sealed and checked for leaks.

**ALL CHIMNEY PIPES AFTER BURNING AND INSTALLING SHOULD BE CLEANED AND INSPECTED ON A REGULAR BASIS DEPENDING ON HOW MUCH YOU ARE BURNING.**

It is the consumer's responsibility to ensure the chimney system is safe and in good operating condition. **The manufacturer will not be held responsible for an accident attributed to a unit connected to a faulty chimney system. Shipping damage must be reported within 10 days of receiving shipment to ensure replacement or repair from a warranty claim through the shipping company.**

**\*IMPROPER INSTALLATION:** The manufacturer will not be held responsible for damage caused by the malfunction of a stove due to improper installation, CHIMNEY FIRES OR OVER-FIRING THE STOVE. It is especially important to use only specified Components when installing. Do not use makeshift methods or material which may compromise the installation. Improper Parts used can cause chimney fire and poor stove performance including exposure to carbon Monoxide. Flame Innovation will not be liable for consequential or indirect damage to property or persons resulting from the use of this product. Consult a professional installer if you have any questions.

## INSTALLATION

1. Remove all parts from inside the stove body including touch up paint, fire poker, etc.

2. Select the proper location for the stove. These appliances must not be installed any closer than the minimum clearance to combustibles noted on the decal on the stove.
3. The stove must be installed on a non-combustible surface.
4. If non-combustible materials have been installed on the walls, obtain the minimum clearances from either the manufacturer of these materials or the local building inspector's office.
5. Install the first section of single wall stovepipe INSIDE the Flue collar on the top of the stove, between the stove and the chimney. We recommend sealing with high-temp., 2000-degree stove pipe sealant. Attach mounting screws in holes provided in Flue collar, Or Install the Chimney Pipe Adapter Part into the stove collar and use 4" Class A HT Pipe from stove to chimney cap.
6. Remember to Pre-drill your fastening points even if you are using a self-drilling screw
7. A clearance of 12 inches (12") between the 4" single wall stovepipe and combustible materials is required. A clearance of 2" can be maintained when using the UL approved Class A Insulated pipe. Check with authorities having legal control in your area with any questions and to verify clearances.
8. All the pipe sections **MUST BE** connected with the male (crimped single wall pipe) end toward the stove.
9. Fasten the stove pipe to the flue collar using three sheet metal screws. Do the same at each additional joint to make the entire installation rigid.
10. Maintain the required diameter flue for the entire installation according to local rules and regulations.
11. It is not recommended to use 90-degree elbows. If you must go out a side wall, then plan to use 45-degree elbows. One inside and one outside. This will not slow the draft as much as 2 90-degree elbows. 90 Degree elbows will slow the amount of draw, and possibly cause smoke spillage. **45-degree elbows are preferred.** It is recommended that no more than two 90-degree bends be used in the stovepipe installation if 90-degree elbows are used.
12. An In-Line damper is not required in this installation in the stove pipe above the stove. Remove the damper plate in the chimney or secure it in the OPEN position if you buy a chimney pipe with a damper inside. **FAILURE TO FOLLOW THE MINIMUM CLEARANCE REQUIREMENTS MAY RESULT IN AN UNSAFE INSTALLATION.**
13. Single wall flue pipe assemblies must not exceed 12 feet (12') in overall length. Single wall flue pipe assemblies for wall tents, camping, etc. must not exceed 12 feet (12') in overall length and pass through a wall or ceiling without the proper clearances to combustibles (most areas 18") and proper metal box separators to surround the pipe and protect the wall and ceiling. Some cases at higher elevations above 5000 ft (about 1.52 km). may need additional Pipe sections.
14. **ALWAYS Check for Leaks**
15. Minimum stove pipe required at 2000 ft (about 609.6 m. Elevation) is 7 FT. **Higher elevations require more exhaust pipe lengths to draft correctly.**

## **INSTALLATION Cont'd**

### **THIS ROOM HEATER MUST BE CONNECTED TO:**

- 1.) A chimney complying with the requirements for Type-HT Chimneys in the Standard for Chimneys, Factory-Built, Residential Type and Building Heating Appliance, UL 103 or**
- 2.) A code-approved masonry chimney with a flue liner.**
- 3.) DO NOT INSTALL IN AN ALCOVE.**
- 4.) DO NOT CONNECT TO OR USE IN CONJUNCTION WITH ANY AIR DISTRIBUTION DUCTWORK UNLESS SPECIFICALLY APPROVED FOR SUCH INSTALLATIONS.**
- 5.) DO NOT INSTALL IN ANY FIREPLACE.**

**Canada: A Chimney connector shall not pass through an attic or roof space, closet or similar concealed space, or a floor, or ceiling. Where passage through a wall or partition of combustible construction is desired. The installation shall conform to CAN/CSA-B365. Installation code for Solid-Fuel-Burning Appliances and equipment.**

#### **CANADA**

**Chimney Must be Labeled CAN/ULC-S629 or Code Compliant Chimney or Single Wall Stainless Steel Chimney where Clearance to Combustibles is Met**

**IT IS RECOMMENDED TO USE 4" CLASS A INSULATED STOVE PIPE. OPTIONAL 2 FT SECTION OF SINGLE WALL PIPE CAN BE USED DIRECTLY OFF THE STOVE AS LONG AS THE WALL IS PROTECTED AND CORRECT CLEARANCES CAN BE MAINTAINED.**

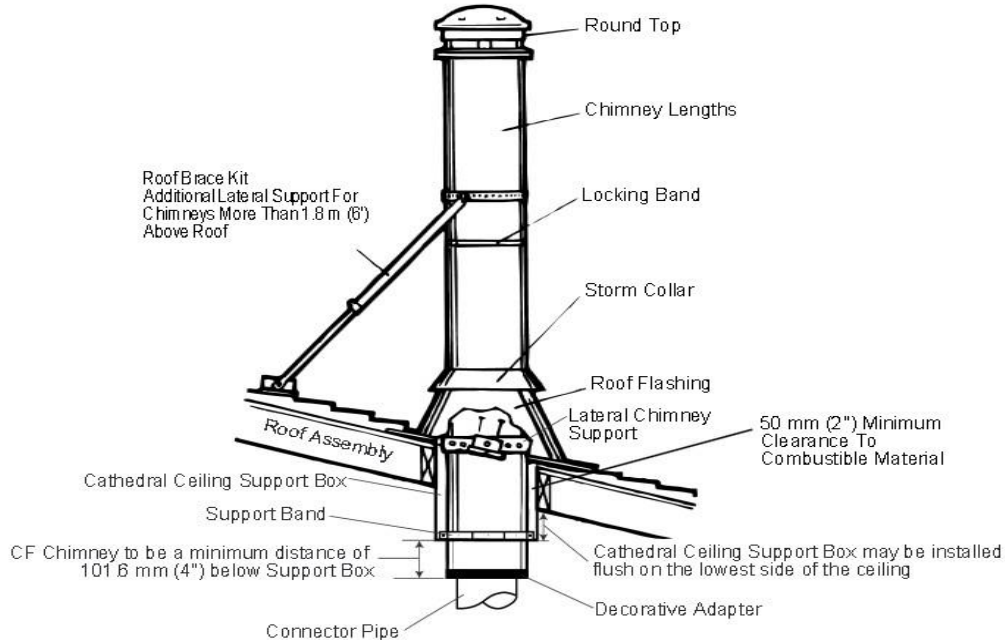
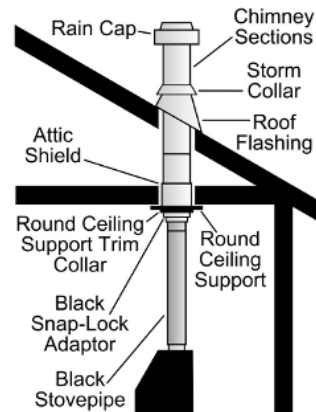
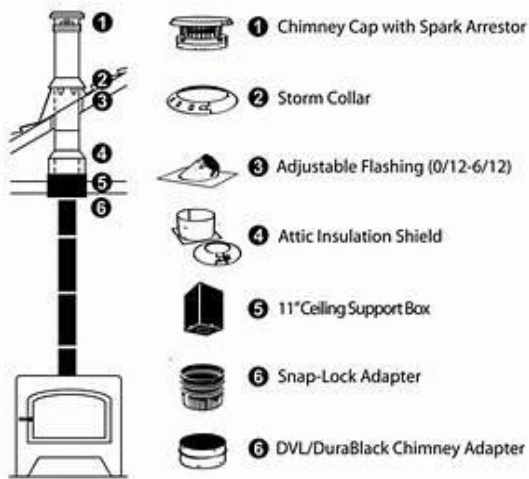
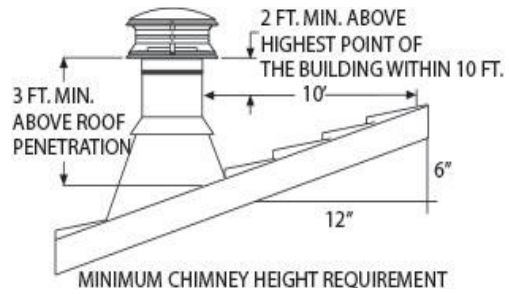

### Examples of single wall 4" to Class A 4" Chimney at ceiling

Note: You must Maintain 18" From Ceiling with single wall Pipe and minimum 12" From walls with 1" Air Gap behind Non-Flammable wall boards.



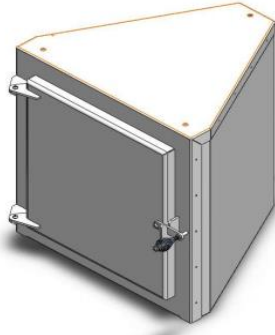

## Corner Storage Cabinet / Pedestal

### FLOOR AND WALL PROTECTION

1. You will not need any floor protection if your floor is constructed of a non-combustible material such as brick, metal, or concrete. If your floor is constructed with a combustible material such as hardwood, carpet, or linoleum, you must place protection between the stove and the combustible material. There are many floor and wall board manufacturers. The type of board you choose should be U.L. rated and a listed Fiber Board. After examining the area you plan to place your stove and determining it requires a board, the next step is to select the proper size. The stove you choose will determine the size board that is required. The approved protector board should be large enough to provide a minimum of eight inches (8") behind the unit, eight inches (8") on either side and sixteen inches (16") in the front (18" Canada) where the door is located. This stove requires a minimum of 42.0" D x 36.25" W for floor protection.
2. **Installation on a Concrete Floor** An appliance mounted on a concrete floor does not require floor protection. Carpeting and any other combustible material must not cover the Floor Protector. If a combustible surface is applied to the concrete floor, a clearance must be maintained equivalent to the area reserved for the floor protector. Floor Protection Foot-Print Minimum Size 42.0" x 36.25"

**Installation on a Combustible Floor** If the appliance is to be installed on a combustible floor or a combustible floor covering, it must be installed on a 1" thick non-combustible millboard floor protector or a durable equivalent, with a "R" factor of no less than "2." The pad must be installed beneath the unit, extending 16" (U.S.) on the side equipped with a door, and 8" on all other sides. The pad must cover any horizontal chimney connector flue runs and extend 2" beyond each side.

### An R-2 Hearth Pad is Required for Free-Standing Installation

Type 2 – Traditional Hearth Pads

Fully non-combustible, with an R-value of **2.24 or 1.592** (R-value information), it provides protection well above the minimum requirements for Type 2 hearth pads (minimum requirement of R-value=1.0).

Your hearth pad is the layer of material that sits between your stove or fireplace and the floor or subfloor under it. Often made of natural stone tile, ceramic tile, thin set cement

board and other building materials, the hearth pad protects the subfloor from the heat of the fire above it. Its R-value, or thermal resistance, tells you how well it insulates the subfloor. To find the R-value, you need to know what materials the hearth pad is made of and their relative R-values, K-values, or C-values. These other two values measure thermal conductivity.

Look at the edge of the hearth pad, so you can see a cross-section of all its materials. If you have already installed the hearth pad, you might have to remove a decorative tile bevel or some other sort of edging to see the cross-section.

Measure the height in inches of each material used in the hearth pad. For example, if the hearth pad has a layer of cement board on the bottom, a layer of thin set in the middle and a layer of ceramic or stone tile on top, measure the height of each layer.

Consult an R-value chart to determine the R-value of each layer. Hearth manufacturers, insulation manufacturers and utility companies may have these charts on their websites or in their stores or offices.

Add the R-values of all the layers in the hearth pad to find the hearth pad's total R-value.

Measure the thickness of any layers of the hearth pad for which you know the K-value. You do not need to measure the layers for which you know the C-value.

Divide 1 by the K-value of the layer. Multiply the result by the thickness of the layer. This gives you, its R-value. For example, if you have a 1/2-inch layer of a material with a K-value of 0.3, divide 1 by 0.3 to get 3.333, then multiply that by 0.5 to get an R-value of 1.667.

Divide 1 by the C-value of a layer. This gives you the R-value. For example, if you have a layer with a C-value of 1.15, divide 1 by 1.15 to get an R-value of 0.87.

Repeat these calculations for any remaining layers. Add the R-values together to get the total R-value for the hearth pad.

## **MASONRY CHIMNEY**

Ensure that a masonry chimney meets the minimum standards of the National Fire Protection Association (NFPA) by having it inspected by a professional. Make sure there are no cracks, loose mortar or other signs of deterioration and blockage. Have the chimney cleaned before the stove is installed and operated. When connecting the stove through a combustible wall to a masonry chimney, special methods are needed. Refer to Combustible Wall Chimney Connector Pass-Throughs.

## **MASONRY FIREPLACE**

There are listed kits available to connect a stove to a masonry fireplace. The kit is an adapter that is installed at the location of the fireplace damper. The existing damper may have to be removed to allow installation.

### **METHOD A.**

12" (304.8 mm) Clearance to Combustible Wall Member: Using a minimum thickness 3.5" (89 mm) brick and a 5/8" (15.9 mm) minimum wall thickness clay liner, construct a wall pass-through. The clay liner must conform to ASTM C315 (Standard Specification for Clay Fire Linings) or its equivalent. Keep a minimum of 12" (304.8 mm) of brick masonry between the clay liner and wall combustibles. The clay liner shall run from the brick masonry outer surface to the inner surface of the chimney flue liner but not past the inner surface. Firmly grout or cement the clay liner in place to the chimney flue liner.

### **METHOD B.**

9" (228.6 mm) Clearance to Combustible Wall Member: Using a 6" (152.4 mm) inside diameter, listed, factory-built Solid-Pak chimney section with insulation of 1" (25.4 mm) or more, build a wall passthrough with a minimum 9" (228.6 mm) air space between the outer wall of the chimney length and wall combustibles. Use sheet metal supports fastened securely to wall surfaces on all sides, to maintain the 9" (228.6 mm) air space. When fastening supports to chimney length, do not penetrate the chimney liner (the inside wall of the Solid-Pak chimney). The inner end of the Solid-Pak chimney section shall be flush with the inside of the masonry chimney flue, and sealed with a non-water-soluble refractory cement. Use this cement to seal to the brick masonry penetration.

### **METHOD C.**

6" (152.4 mm) Clearance to Combustible Wall Member: Starting with a minimum 24 gage (.024" [.61 mm (about 0.02 in)]) 6" (152.4 mm) metal chimney connector, and a minimum 24 gage ventilated wall thimble which has two air channels of 1" (25.4 mm) each, construct a wall pass-through. There shall be a minimum 6" (152.4) mm separation area containing fiberglass insulation, from the outer surface of the wall thimble to wall combustibles. Support the wall thimble, and cover its opening with a 24- gage minimum sheet metal support. Maintain the 6" (152.4 mm) space. There should also be a support sized to fit and hold the metal chimney connector. See that the supports are fastened securely to wall surfaces on all sides. Make sure fasteners used to secure the metal chimney connector does not penetrate chimney flue liner.

## METHOD D.

2" (50.8 mm) Clearance to Combustible Wall Member: Start with a solid-pack listed factory-built chimney section at least 12" (304 mm) long, with insulation of 1" (25.4 mm) or more, and an inside diameter of 8" [51 mm (about 2.01 in)] larger than the [152.4 mm (about 6 in)] chimney connector). Use this as a pass-through for a minimum 24-gage single wall steel chimney connector. Keep solid-pack section concentric with and spaced 1" (25.4 mm) off the chimney connector by way of sheet metal support plates at both ends of chimney section. Cover opening with and support chimney section on both sides with 24 ga. minimum sheet metal supports. See that the supports are fastened securely to wall surfaces on all sides. Make sure fasteners used to secure chimney Flue liner.

### NOTES:

1. Connectors to a masonry chimney, excepting method B, shall extend in one continuous section through the wall pass-through system and the chimney wall, to but not past the inner flue liner face.

1. A chimney connector shall not pass through an attic or roof space, closet or similar concealed space, or a floor, or ceiling.

2. **THE Mini Me Pellet Model DOES NOT HAVE A REAR EXHAUST OUTLET, THEREFOR DO NOT INSTALL IN OR UP A BUILT IN FIREPLACE / HEARTH FIREPLACE. DO NOT MOUNT THE STOVE IN FRONT OF A BUILT IN FIREPLACE AND RUN THE CHIMNEY UP THROUGH THE OPENING AT GROUND LEVEL. ONLY INSTALL AS DESCRIBED ABOVE BY A THROUGH WALL PENETRATION TO THE CHIMNEY LINER.**

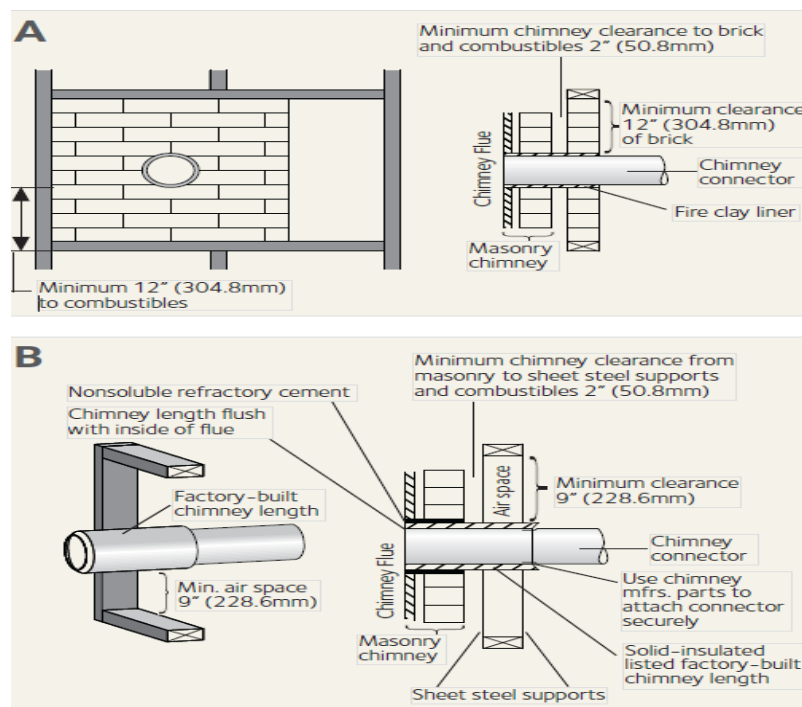

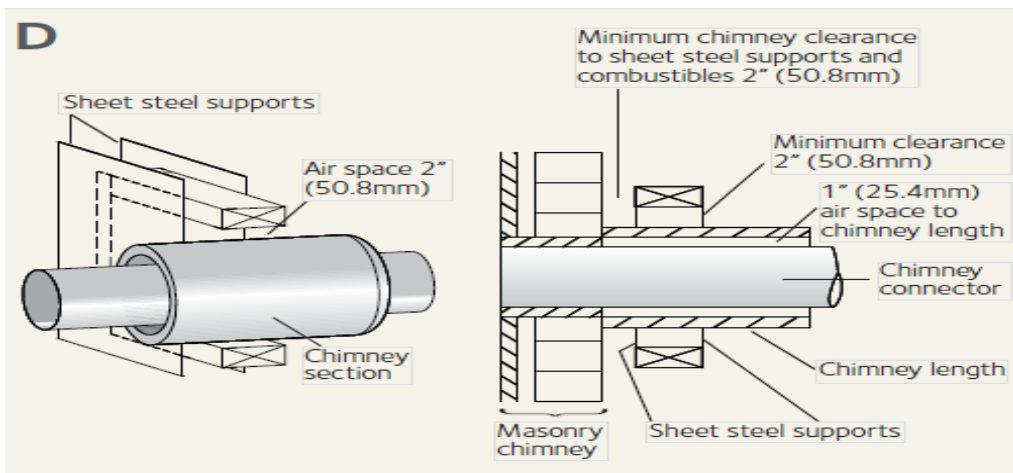
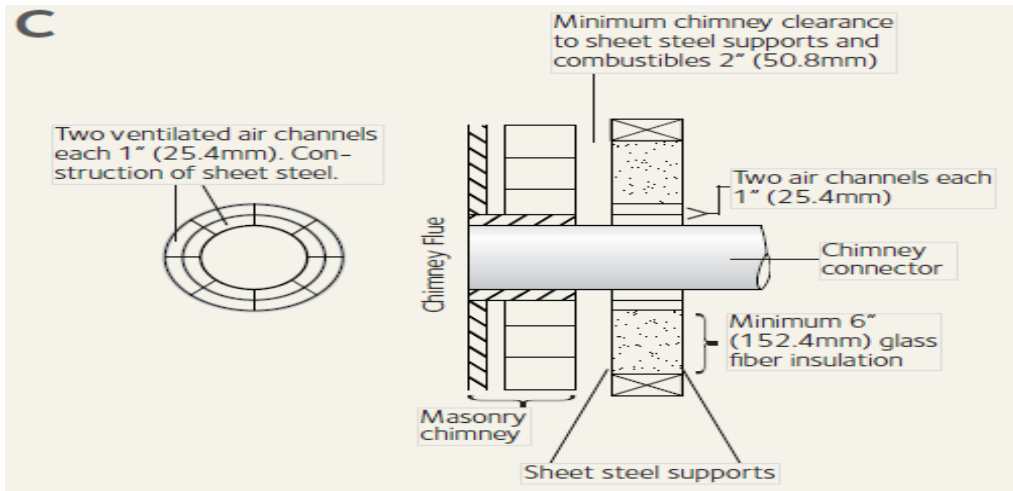

***Class A Pipe from 18" before ceiling or wall penetration above 2 ft single wall pipe off stove. Continue use of Class A pipe through ceiling and outside. Wall Exit use 45-degree elbow inside, Class A through wall and 45 class A degree elbow outside and class A Vertical to Chimney Cap.***

# Clearance to Combustibles USA

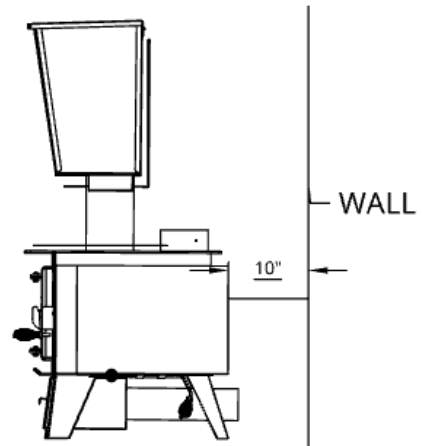
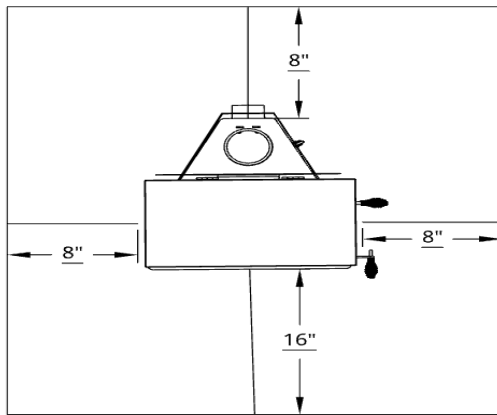
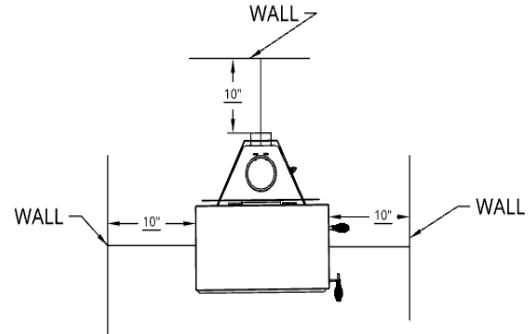
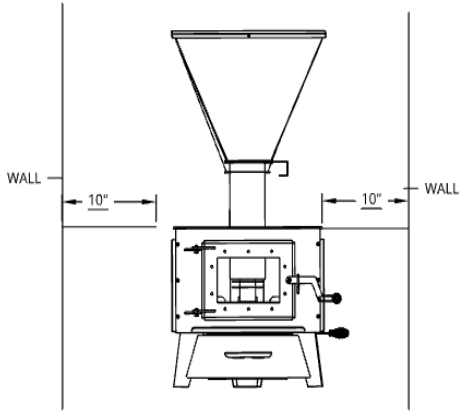

## Floor Protection R-2

# Clearance To Combustibles Canada

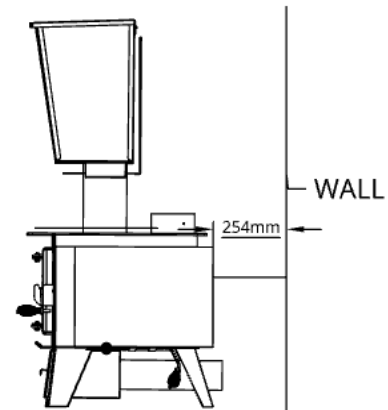
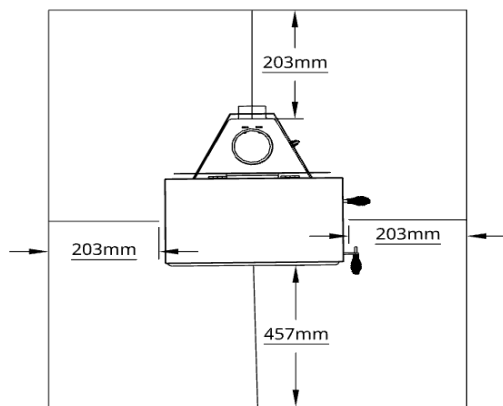
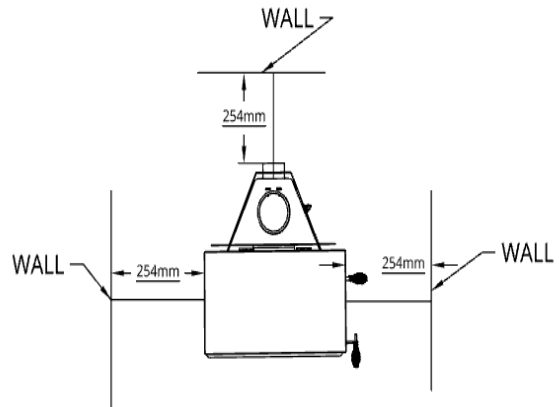
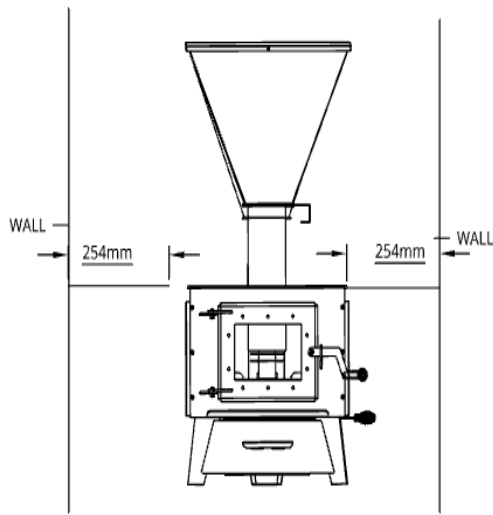

## Floor Protection R-2

**Canada:** To comply with CSA B365, Installation Code for Solid-Fuel-Burning Appliances and Equipment, any combustible covering beneath the appliance and/or within the area extending horizontally at least 450 mm (18 in) beyond the appliance on any side equipped with a door, and at least 200 mm (8 in) beyond the appliance on other sides, shall be protected by a continuous, durable, non-combustible pad that will provide ember protection. The 450 mm (18 in) ember protection required on any side with a door shall extend for the full width of the appliance plus the 200 mm (8 in) required on each side of the appliance without a door. Where an appliance is installed less than 200 mm (8 in) from a wall, the ember pad needs only extend to the base of the wall. An ember pad shall not be placed on top of a carpet unless the pad is structurally supported to prevent displacement and distortion.

**NOTE:** Do not install the chimney directly at the outlet of the appliance. A chimney connector (flue pipe) is required unless the appliance is specifically approved for that type of installation.

- If the stove is installed in a transportable building, the chimney must be removed.
- Completely seal all penetrations with high temp. sealant of the chimney and silicone sealant for fresh air holes to maintain continuity of the air barrier system.

#### **Wall Protection for “Free Standing” Installation**

In some areas local codes may require thirty-six inches (36”) from a combustible, therefore it is important that you check with local officials. If you need to place your unit closer to a combustible wall, some protection will be necessary. A one-inch (1”) air space must be between the board and the wall. If you have a ceiling flue hook-up, you will need protection from the floor to the ceiling if you do not meet the normal clearances. If you have a wall flue hook up, you will need wall protection at least twelve inches (12”) above the wall thimble.

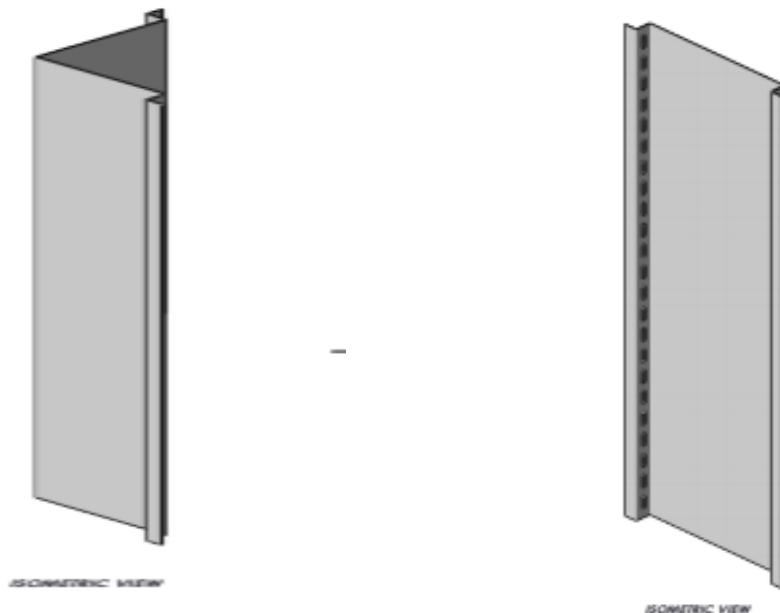



## Outside Air Connection

The stove can accept a 3-inch aluminum flex tube for outside air under the stove draft. Make sure when connecting the fresh air tube to the outside that you cover the end with a screen of some sort, but not a screen that would restrict air in-flow. Utilize a screen with wider openings. The firepot air inlets are removable to clean the stove, and come standard with a built-in ash pan and fresh air inlet / outlet in the back leg of the stove.

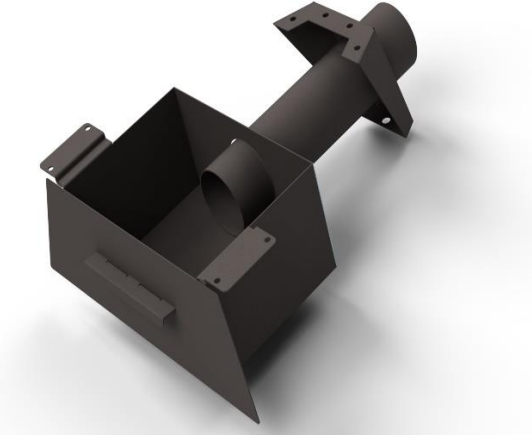

## BUILDING A FIRE

To start the fire, make sure the ash is out of the pot by removing the front bricks and pushing the ash to the side or remove air inlets and push ash through the openings with the damper all the way out so it will land in the ash pan below.

## BUILDING A FIRE Cont'd

1. Replace the front bricks and air inlets you removed.
2. Pull the locking handle under stove out and slide towards the front of the stove into the locking position for your damper to set up against to set the EPA Mandated lowest setting on the stove.
3. Pull out damper handle to the second line on the handle (HIGH Setting.)
4. Fill up the hopper with the number of pellets you want to burn.
5. Use breaching tool. (See note)

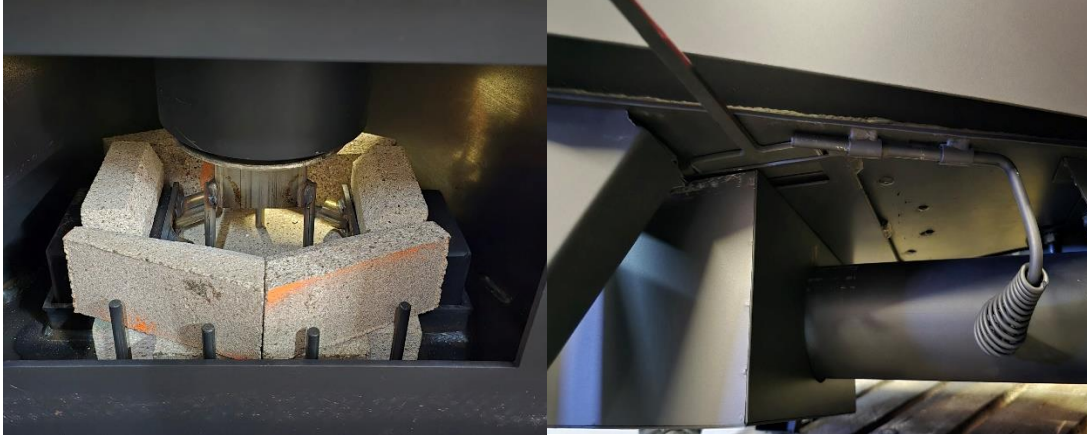

**USE PROVIDED PELLET BREACH TOOL WITH THE SPRING END UP. RUN DOWN THROUGH THE PELLETS WITH THE ROD AND INTO THE AREA OF THE PELLET ADAPTER AFTER FILLING TO THE BOTTOM OF THE HOPPER TO ENSURE THAT YOU DID NOT GET A BREACH IN PELLETS BEFORE LIGHTING THE FIRE AND FILLING THE HOPPER WITH DESIRED AMOUNT OF PELLETS YOU WANT TO BURN.**

Open the door of the stove and use a propane torch to light the pellets on the left and right and center of the pot moving back and forth. Hold the torch on each section for about 20 to 30 seconds and repeat. Close the door and see if you have a flame. If you do, then the stove will continue to light on its own. If you do not have a flame after closing the door, then repeat the lighting procedure. Make sure to close the door immediately after starting the fire. After a couple of times lighting the stove, you will figure out what works best for you. Slide the damper to the medium position between the 2 lines on the damper slide. The stove burns best with the damper in the center position between the 2 lines on the damper slide for a medium burn.

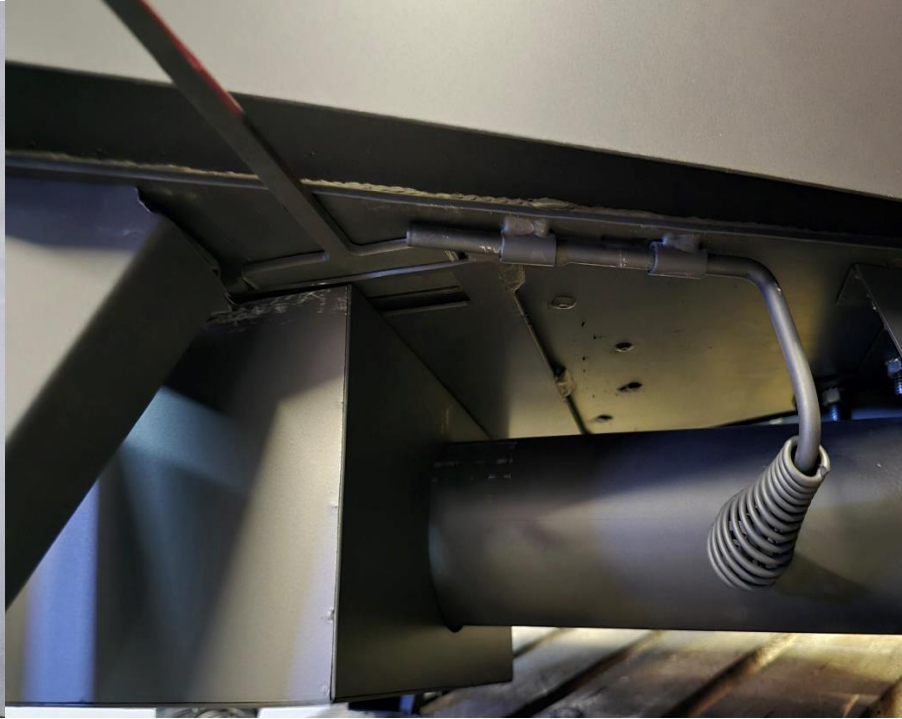
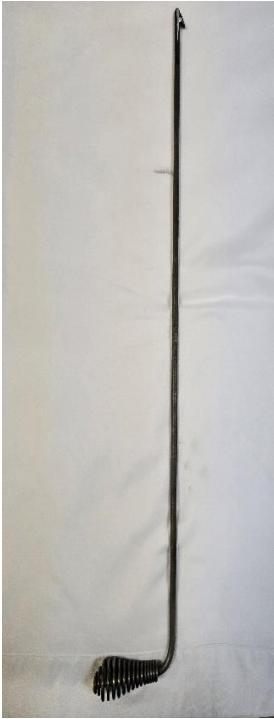

Pellet Breach Tool    Damper Lock / Stop Position @ lowest setting. Move to slide closed.

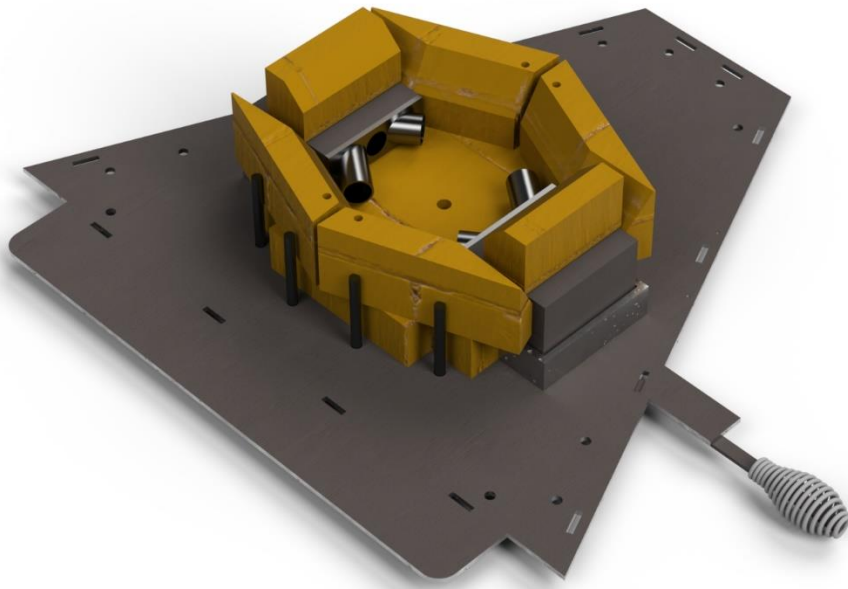

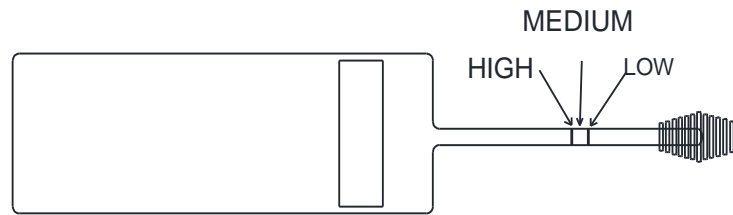

(Damper can be moved slightly to the first mark under the indicator for lower burning, but it is only recommended for short periods. Risk of burning up the feed tube after extended periods of burn time unless you scoop the ash out of the pot regularly using the ash scoop provided. The second mark on the damper handle is the high setting. The damper stop pull rod under the stove must always be in the locked position so the stove can not be turned down lower than the EPA Mandated setting. Different lengths of chimney, and the 2 types of chimneys used for configuration, elevation, and temperature play roles in how the fire will burn.

## FIRST FIRE

Remember to ventilate well. The stove paint will “cure” as you burn and smell some. Flat spots on the painted surface are normal. Shiny spots on the painted surface (before burning) are normal.

1. Do not use a grate or elevate the fire inside the firebox.
2. Use only Natural pellets, preferable soft wood blends with low ash content marked on the bag. You will find a brand you like the best. (Hardwood pellets burn cooler and are not recommended)
3. When the stove is used for the first time, solvents in the paint will smoke off as the stove “cures.” As well as smoke coming off the stove pipe.

**NEVER USE PELLETS THAT HAVE ADDITIVES IN THEM LIKE WAX, OILS, OR OTHER BINDING AGENTS. PURE SAWDUST PELLETS ONLY. THE USE OF THESE OTHER TYPES OF PELLETS CAN CAUSE A FIRE THAT IS OUT OF CONTROL VERY QUICKLY DUE TO THE ADDITIVES.**

**CLEAN AND INSPECT YOUR CHIMNEY REGULARILY AND WATCH OUTSIDE FREQUENTLY TO LOOK FOR SMOKE TO INSURE CORRECT DRAFT PLACEMENT FOR EFFECTIVE CLEAN EFFICIENT BURNING.**

ALWAYS STORE YOUR PELLETS IN A WELL-VENTILATED AREA AWAY FROM DIRECT MOISTURE.

**DO NOT BURN:** Pellets with Additives, Treated Wood, Regular Wood, Garbage, Solvents, Trash, Cardboard, Colored Paper, or Coal. Just Pellets. (spiders are ok)

NEVER USE GASOLINE, GASOLINE-TYPE LANTERN FUEL, KEROSENE, CHARCOAL LIGHTER FLUID, OR SIMILAR LIQUIDS TO START OR 'FRESHEN UP' A FIRE IN THIS HEATER. KEEP ALL SUCH LIQUIDS WELL AWAY FROM THE HEATER WHILE IT IS IN USE.

### SHUTTING DOWN THE STOVE WITH PELLETS IN THE HOPPER

**Note: It is always best to let the stove burn out of pellets instead of using the tool to stop the pellet feed. Only put in enough pellets to burn the length of time you want to burn.**

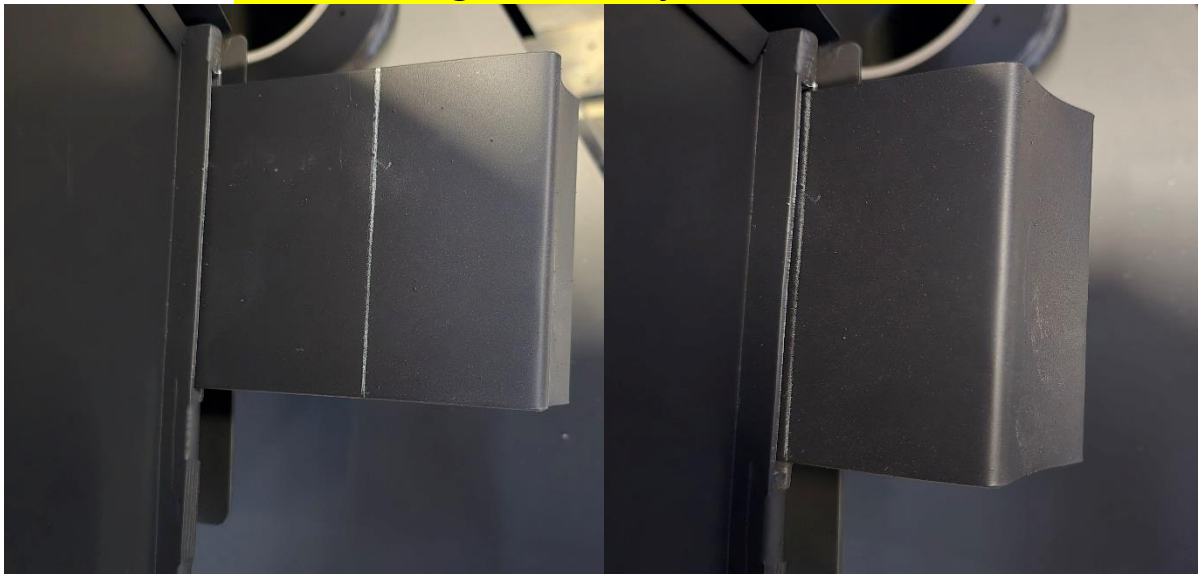

The Mini Me can be shut down with pellets still inside the hopper. **Do not touch the damper setting. The damper must be left open to let the stove burn while it finishes the pellets inside the feed tube.** Slide the pellet shutoff tool into the slot at the bottom right side of the hopper and push in until the tool reaches the shutoff line scribed into the tool. You may have to wiggle it and slide it side to side to get it to go into the slot, but it will work. Leave the stove running as-is without moving the damper to the closed position. If you slide the damper lock out of the way and slide the damper closed, it will smoke and not burn correctly.

## CLEANING THE STOVE

The Mini Me Pellet has a removeable pellet adapter and bricks.

1. The pellet adapter must be removed using the provided tool w/ hook. Clean and inspect the adapter at least once a week.
2. Use a wire brush to remove any debris inside of the adapter. Keeping the surface smooth will help with breaching of the pellets.
3. Remove the top bricks and pull the damper slide tool out from under the stove to remove the damper.
4. Scrape the ash into the air inlet holes to land in the ash pan below. If you can vacuum the stove out with an approved ash vac it will be easier and faster. (See ash disposal)
5. Replace the damper and move the damper slide / stop to the locking position and pull the damper back to the stop to be ready for the next burn
6. Replace the bricks in the firebox.
7. Replace the pellet adapter making sure the 2 leg posts on the corners are facing the door with the center post in the back.

NOTE: You can use the tool provided to clean out the pot while in operation to scoop some ash out. Make sure to slide in the pellet stop tool below the hopper before opening the door to eliminate smoke rising through the hopper or pellets burning up the tube.

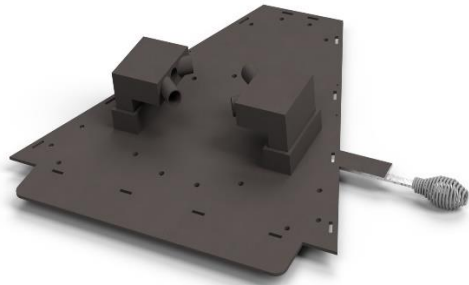



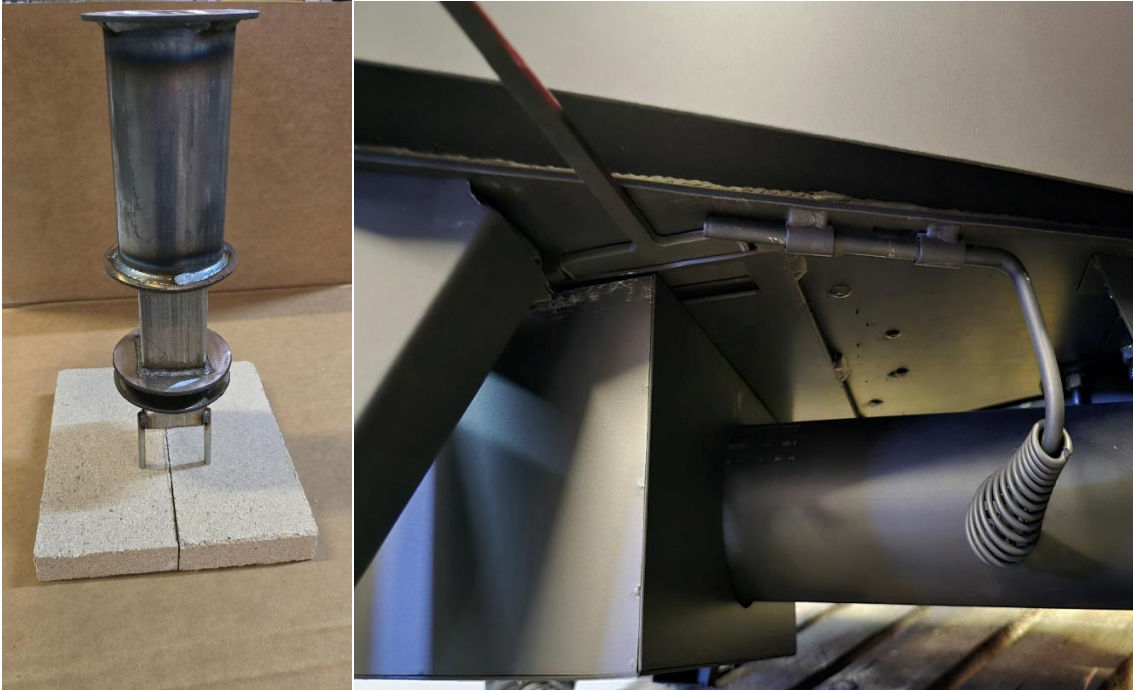

### *Pellet Adapter*

1. Reach under the cooled down stove and pull up on the damper lock spring.
2. Slide the spring handle towards the rear of the stove to the stopped position.
3. Pull out the damper handle and remove it from the stove.
4. Remove the front and side bricks.
5. Pull out the air inlet tubes including the round tube inserts and place outside the stove.
6. Slide the ash in the burn pot area into the air inlet holes emptying the ash into the ash pan below the stove.
7. If a full cleanout is required, remove the back 2 bricks, and use an approved ash vacuum to remove all the rest of the ash from the stove.
8. Replace the back 2 bricks making sure they are installed without any gaps in between them.
9. Set the air inlets back into the air chamber holders.
10. Place the round tube inserts back into the air inlets, making sure the longer tubes on each are opposite. **See Pics**
11. Place front bricks and side bricks back into position making sure there are no gaps.
12. Empty Ash Pan and vacuum contents into an approved metal container to dispose of any hot ashes.

13. Inspect ashes before dumping them out of your approved container for heat, and live coals.

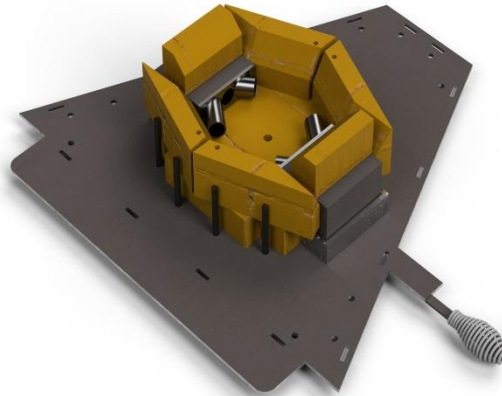

(See Ash Disposal Section)

**ALWAYS INSPECT THE PELLET ADAPTER WHEN THE STOVE IS OUT OF PELLETS AND COOLED. LOOK FOR ANY HARD ASH DEBRIS INSIDE THE ADAPTER IN THE LOWER SECTION. USE METAL BRISTLE BRUSH TO CLEAN OUT THE ADAPTER AND RE-INSTALL AS DESCRIBED IN THE MANUAL.**



Ash Pan is shown with mounting brackets, and fresh air intake in the back leg of the stove.

**ASH DISPOSAL** Regularly inspect the ash build-up in your unit and remove, as necessary. Ashes can be removed from the unit by shoveling out bottom to ash pan after removing the front firebrick. Use an ASH VACUUM if desired when the stove is completely out.

**Caution:** The ashes can be extremely hot!! Never remove red-hot ashes from the appliance; allow ashes to cool before cleaning. Ashes should be placed in a metal container with an airtight lid. The ashes should be placed outside on a noncombustible surface and completely away from any combustible materials. The ashes should remain in the airtight container until they have completely cooled.





## **MINI ME PELLETT ADAPTER INSTALL INSTRUCTIONS**

Remove pellet adapter from packaging and make sure there is nothing in the center to obstruct the pellets after installation.

Place your fire poker tool across the fire pot to catch the pellet adapter when it slides down the tube.

Open the lid on your Mini Me Pellet stove and insert the pellet adapter into the tube with the 3 prongs facing down and the round disc with the round hole facing up.

Slide the pellet adapter down as far as you can by hand and then let it go. The pellet adapter will stop when it hits the fire rod tool. Lift and slide the tool out of the stove. You may have to lift the pellet adapter up slightly to slide the tool out. The 2 legs that are on the corners of the pellet adapter should face the door with the other leg being center in the back.

Make sure the fire pot is clean and then fill the hopper with the desired number of pellets. **Remember to use the pellet breach tool before filling up the hopper.**

Close the lid and set the damper to the medium position and use a torch (**BY FAR THE BEST WAY TO LIGHT THE STOVE**) or gel or preferred lighting method to light the pellets. If you are lighting it with a torch, make sure to close the door and look for flames. If there are not visible flames, open the door and continue to light with the torch until it stays lit when you close the door. Leave the damper in the middle setting.

Let the stove get to temperature. Do not let the flame be lazy in movement. You want the flame to be active and vibrant to keep creosote levels down and avoid burning up into the tube.

Keep the fire pot clean between burns. This really helps with how the stove will perform. Depending on the size of your ash vac you can clean the pot out by using the tool provided or removing a couple of the bricks and pushing the ash out of the pot. Only vacuum when the stove is out and cold.

Note: When buying pellets, look at the size of them. If there are a lot of really long pellets visible in the bag, then look at another brand of pellets with shorter length pellets. This will help the stove not to clog. If it does clog you can tap on the tube, open the door, and tap on the feet of the pellet adapter, or run the pellet breach tool down through the center of the hopper and into the pellet adapter area.

**\*\*\*\*\* SPECIAL NOTE: LEAVE THE DAMPER OPEN TO BURN THE PELLETS THAT ARE LEFT IN THE FIREPOT AND LET THE STOVE BURN OUT. DO NOT CLOSE THE DAMPER**

## DRAFT / AIR CONTROLS

1. Pull the damper handle out past the high mark under stove out and slide the other handle under the stove up and forward towards the front of the stove until it stops. This will lock the damper into the lowest setting when you slide the damper back in so it cannot be run lower than the EPA mandated setting.
2. Pulling the damper out runs the stove on high. See marks on damper and align with the indicator plate for correct adjustment.
3. We suggest to run the damper in the spot located between the high mark and the low mark for full time burning.



## EPA Efficiency

EPA Testing Efficiency was determined in accordance with CSA B415.1 using HHV at maximum, medium, and minimum burn rates. This pellet heater burns efficiently, (See Chart page 1), on all settings, however using pellets that are not dry or are poor quality will directly affect how the stove performs and can significantly reduce efficiency. Locating the stove in the most central location of the structure for more even heating will result in the best efficiency of the fuel that you put in this pellet heater. This pellet heater has been tested and found to produce minimal smoke and CO, but under certain conditions both will be produced. A CO / "Carbon Monoxide" detector is recommended in the area of the heater and or fuel storage areas. Areas containing hydronic heaters, or other burning devices should have Carbon Monoxide detectors.

## GLASS CARE

The following use and safety tips should be observed: **NEVER POUR WATER ON HOT GLASS**

1. Inspect the glass regularly for cracks or breaks. Surface scratches are acceptable and normal, but if this glass becomes cracked in any area, the unit should be shut down and the window replaced with high-temperature Neo-Ceram glass ONLY. (5.50" x 8.50")
2. Do not slam the door or otherwise impact the glass. When closing doors, make sure that foreign objects do not protrude and impact the glass.
3. Do not clean the glass with materials which may scratch (or otherwise damage) the glass. Scratches on the glass can develop into cracks or breaks.

4. Never attempt to clean the glass while the unit is hot. If the deposit is not very heavy, normal glass cleaners are adequate with a plain, non-abrasive scouring pad. Heavier deposits may be removed with a razor blade scraper.
5. NEVER put substances that can ignite explosively inside the unit, since even small explosions in confined areas can blow out the glass.
6. Inspect the glass and door seal periodically to ensure proper seal. If the gaskets become frayed or worn, replace them immediately. Contact your dealer or Customer Service at (509)-993-3767 OR (208)-660-3109 OR [Info@509Fab.com](mailto:Info@509Fab.com) for approved replacement parts.

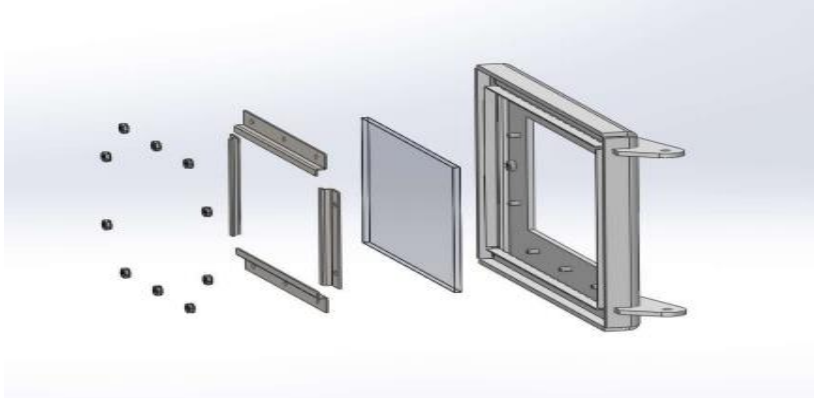

### **Glass Gasket Replacement**

After extensive use, the sealing material which provides glass and door seal may need to be replaced if it does not sustain its resilience. Inspect the glass and door seal periodically to ensure proper seal. If the gaskets become frayed or worn, replace them immediately.

The following steps should be followed for replacement of the glass gasket:

1. Ensure that the appliance is not in operation and is thoroughly cooled.

2. Remove the screws and glass clip Brackets.
  3. Lift glass out from glass clips.
  4. Remove the old gasket and clean the glass.
  5. Replace the new gasket, starting at the bottom of the glass and working along the edges. Be sure to center the gasket channel on the glass.
  6. Trim the gasket to length and butt the ends together.
  7. Replace the glass in the door, being sure not to overtighten the nuts, this will break the glass.
- REPLACE GLASS ONLY WITH HIGH-TEMPERATURE NEO-CERAM OF THE PROPER SIZE AND THICKNESS. 5.50" X 8.50" You may order parts and options on our web site: [FlameInnovation.com](http://FlameInnovation.com) or by calling (509) 993-3767 OR (208) 660-3109 OR [Info@509Fab.com](mailto:Info@509Fab.com)

### **Door Gasket**

The door gasket is ¾" Rope Gasket. You will have to dig the gasket out of the channel and then clean all the old gasket cement out of the channel for the new sealant to adhere correctly when putting in new fire rope. Use only ¾" Fire Rope to replace the door gasket. You can find it on our website if you cannot find it locally. Use high Temp Stove Gasket Sealer on all 3 sides of the channels to secure rope in place. Place a weight, like a big book, over the gasket overnight and then re-install the door. IMPORTANT NOTE: A clean surface is crucial to sealing your new gasket properly. DO NOT Try and re-seal over old gasketing Cement.

### **CREOSOTE**

When Pellets are burned slowly, they produce tar and other organic vapors. These combine with moisture to form creosote. Creosote vapors condense in the relatively cool chimney flue of a slow-burning fire – as a result, creosote residue accumulates on the lining of the flue. If ignited, this creosote makes an extremely hot fire. The chimney should be inspected regularly during the heating season to determine if a creosote build-up has accumulated. If it has, the creosote should be removed to reduce the risk of chimney fire.

#### **WAYS TO PREVENT AND KEEP UNIT FREE OF CREOSOTE**

1. Burn with the air control at the set position between the high and low mark or towards the high mark if wanting mor heat. **REMEMBER IT TAKES ABOUT AN HOUR FOR THE STOVE TO SPEED UP OR SLOW DOWN BECAUSE WE ARE HEATING UP THE METAL OR COOLING IT DOWN.**
2. Do not over fire the stove OR RAISE THE PELLETS ADAPTER FOR MORE FUEL.
3. **BURN DRY PELLETS ONLY.**
4. Establish a routine for fuel, burning and firing technique. Check daily for creosote build-up until experience shows you how often you need to clean to be safe. Keep in mind that the hotter the fire, the less creosote is deposited, and weekly cleanings may be necessary in milder weather, although monthly cleanings may be enough in the coldest months. Contact your local authority for information on how to handle a chimney fire and have a clearly understood plan to handle a chimney fire.

#### **WARNING: THINGS TO REMEMBER IN CASE OF A CHIMNEY FIRE:**

1. **CLOSE DRAFT CONTROL.**

1. a. SLIDE IN THE PELLET STOPPER IMMEDIATELY.
2. CALL THE FIRE DEPARTMENT.

## BRICK CARE AND LAYOUT

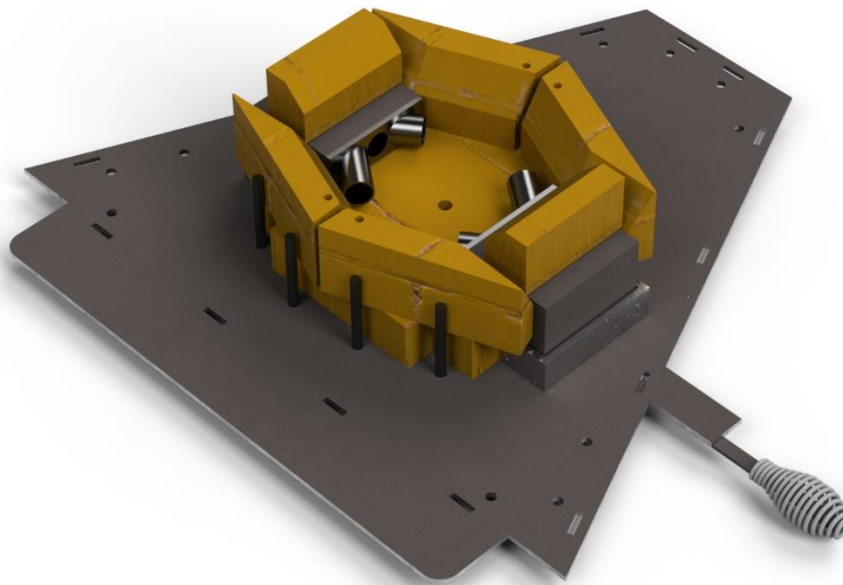

**Inspect your bricks each time you start a fire for correct placement, checking for broken or dislodged bricks. If broken or dislodged bricks are found, they need to be replaced in position or replaced entirely if damaged.**

### **What can cause a poor draft?**

There are several common factors that can contribute to poor draft in a stove.

#### **A. Atmospheric Pressure and Air Supply**

Atmospheric pressure affecting the draft from a chimney can be outside the home, inside the home, or both. Outside the home, a high-pressure (clear and cool) day creates a better draft in the chimney than a low-pressure (overcast and damp) day. Inside the home, household appliances, such as forced-air furnaces or clothes dryers, compete for air, often resulting in inadequate amounts of air available to fuel a fire and creating a condition known as negative pressure. Extreme conditions of negative pressure can cause the combustion by-products to be drawn from the chimney and into the house. This condition is commonly known as “down drafting.”

#### **B. Air Availability**

There are several factors that can affect the amount of air available in the home. Increased amounts of insulation, vinyl windows, extra caulking in various places and door seals can all keep heat in but may also make a home too airtight. If you are in doubt as to whether there is sufficient air in your home for your stove, refrain from using those appliances known to consume air when possible or open a door or a window to allow some air to enter the home.

#### C. Environmental Conditions

Towering trees, a low-lying house location (such as in a valley), tall buildings or structures surrounding your house and even windy conditions can cause poor draft or down drafting.

#### C. Cold Chimney Temperature

Avoid cold chimney temperatures by burning a hot fire for the first fifteen to forty minutes after building a fire, being careful not to over-fire. If any part of the chimney or parts of the stove start to glow, you are over-firing the stove. Where possible, install a temperature gauge on the chimney so temperature drops can be seen.

#### D. Chimney Installation and Maintenance

Avoid using too many elbows or long horizontal runs. If in doubt, contact a chimney expert and/or chimney manufacturer for help. Clean your chimney, rain cap(s) and especially the spark arrester regularly to prevent creosote build-up – which can significantly reduce chimney draw and possibly create a chimney fire.

#### **Should I close or open the air control fully when shutting down the stove?**

When shutting down the stove. Leave the damper in the MEDIUM position. This will allow chimney temperatures to remain as high as possible for as long as possible. Remember, cold chimney temperatures create creosote. Burning all the fuel out of the stove is the best way to leave your stove between fires.

**NEVER POUR WATER ON THE FIRE, IN THE FIRE, OR ON THE STOVE TO EXTINGUISH FLAMES. TURN THE DAMPER TO THE OFF POSITION** BY SLIDING THE HANGING HANDLE UNDER THE STOVE UP AND TOWARDS THE BACK OF THE STOVE TO UNLOCK THE LOW SETTING SO THE DAMPER WILL SLIDE PAST IT AND COMPLETELY SHUT OFF THE AIR TO THE FIRE **AND INSTALL THE PELLET SHUT OFF SLIDE PLATE AS SOON AS POSSIBLE.**

**NOTE: This Manual is intended as an aid and does not supersede any local, state or like requirements. Check with officials or authorities having legal control in your area.**

**IF INSTALLED IN A MOVING STRUCTURE, IT IS HIGHLY RECOMMENDED TO TAKE OFF YOUR CHIMNEY CAP AND INSTALL A PLUG BEFORE BEING MOBILE IN YOUR STRUCTURE TO AVOID ASH BLOWING INSIDE THE STRUCTURE.**

**NEVER MOVE THE STRUCTURE WITH A LIT FIRE.**



Chimney Plug Shown for Reference

**NOTE:**

Parts and accessories are also available on our web site: [Flameinnovation.com](http://Flameinnovation.com)

If you have any questions or problems, contact the Manufacturer or Dealer.

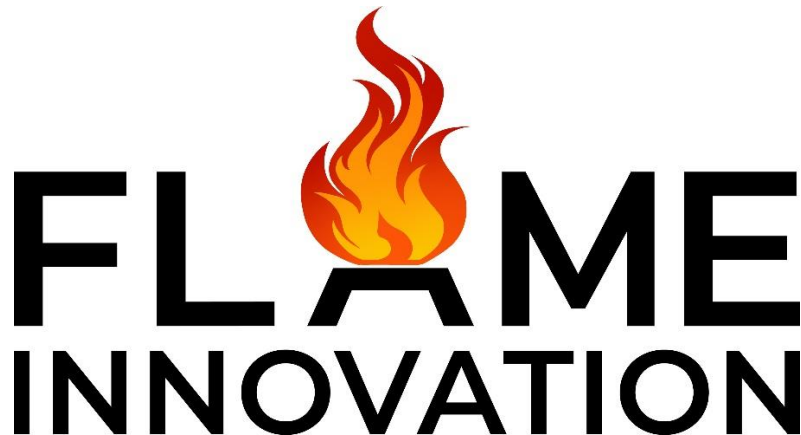

509 Fabrications, Inc.  
DBA, Flame Innovation  
6512 W. Seltice Way  
Post Falls, ID 83854  
509-993-3767  
208-660-3109  
[Info@509Fab.com](mailto:Info@509Fab.com)